

Assemble Hirose connector according to WP0052

Hirose - RM15TPD10S(71)		
COLOUR	PIN No.	FUNCTION
BLUE	1	X OUT
YELLOW	2	Y OUT
WHITE	3	Z OUT
GREEN	4	PGND
VIOLET	5	TEST
RED	6	+12V SUPPLY
BLACK	7	-12V SUPPLY
BROWN	8, 9, 10*	SGND

* PINS 8, 9 AND 10 INTERNALLY CONNECTED TOGETHER IN THE CONNECTOR

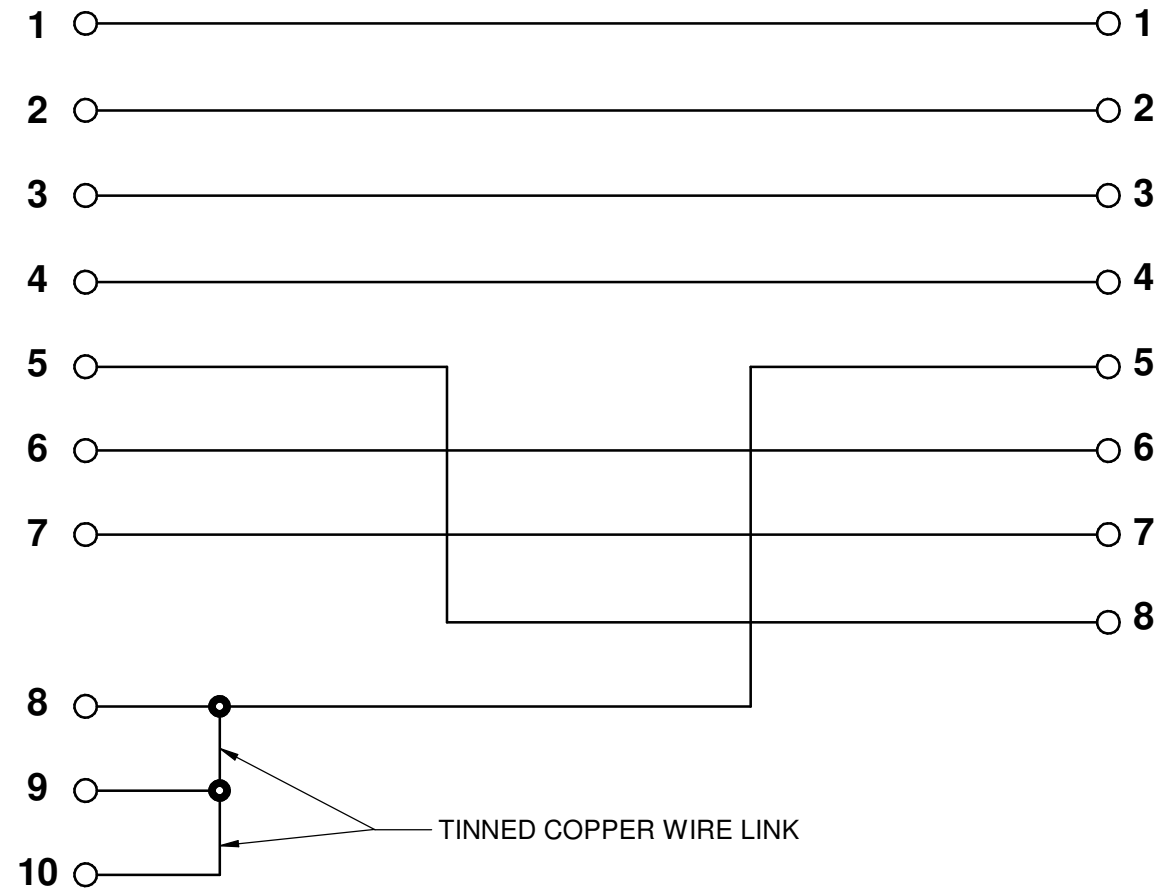

Fischer - AL-2211-S-1031-A010-SR-11-11		
COLOUR	PIN No.	FUNCTION
BLUE	1	X OUT
YELLOW	2	Y OUT
WHITE	3	Z OUT
GREEN	4	PGND
BROWN	5	SGND
RED	6	+12V SUPPLY
BLACK	7	-12V SUPPLY
VIOLET	8	TC
N.C.	9 & 10	

<p>THIS DOCUMENT AND THE INFORMATION CONTAINED IN IT IS COMMERCIAL IN CONFIDENCE AND © BARTINGTON INSTRUMENTS LTD AND/OR ITS LICENSORS. NEITHER MAY BE REPRODUCED, COPIED OR TRANSMITTED TO ANY THIRD PARTY, IN EACH CASE IN ANY MEDIUM, WITHOUT THE PRIOR WRITTEN PERMISSION OF BARTINGTON INSTRUMENTS LTD.</p>	<p>TITLE</p> <p>Mag-13MS & MC Cable Assembly</p>	PROJECT No D1309	
		DRAWN	<i>M Khaled</i>
<p>ASSEMBLY PARTS LIST No. PL3377</p> <p>THIRD ANGLE PROJECTION</p> <p>UNTOLERANCED DIMENSIONS</p> <p>LINEAR: XX ±0.3mm XX.X ±0.1mm XX.XX ±0.05mm</p> <p>ANGULAR: XX ±0.5° XX.X ±0.1° XX.XX ±0.05°</p>	<p>CHECKED</p> <p><i>Daniel Cetnik</i></p> <p>23/03/2018</p>	SAGE/PART No SC-03-10-7178/xxxm	
		DRAWING No DR3377	ISSUE 7